



Ravaglioli

COMPANY WITH
QUALITY SYSTEM
CERTIFIED BY DNV GL
= ISO 9001 =



**HEAVY DUTY
5500 KG**



60
SINCE 1958

KPN 255LIKT / 5500 kg

Modello equipaggiato con **4 bracci extra lunghi a tre stadi**: ideali per il sollevamento di furgoni e furgonati a passo lungo incluso Mercedes Sprinter e VW Crafter.

*Model equipped with **four extra long three-stage arms**: ideal to lift long wheel-base vans like Mercedes Sprinter and VW Crafter.*

Modell mit **vier zweifach ausziehbaren extra langen Armen** ausgestattet: ideal zum Heben von Lieferwagen auch mit langem Radstand wie Mercedes Sprinter and VW Crafter.

*Élévateur équipé de **quatre bras extra longs à 3 étages**: idéal pour le levage de fourgons à châssis long inclus les Mercedes Sprinter and VW Crafter.*

Modelo equipado con **4 brazos extra largos de tres extensiones**: ideal sea para el levantamiento de furgonetas normales y de chasis largo incluido Mercedes Sprinter and VW Crafter.

KPN 255LIKTA / 5500 kg

Versioni con **due bracci lunghi a 3 stadi e due a 4 stadi**, consentono caricabilità ottimale anche per le autovetture.

*Models equipped with **two long 3-stage arms and two long 4-stage arms**, to allow easy lifting of large cars.*

Ausführungen mit **zwei zweifach und zwei dreifach ausziehbaren langer Armen**, um eine optimale Aufnahme von PKs auch zu garantieren.

*Versions équipées de **deux bras longs à 3 étages et deux à 4 étages** pour garantir aussi le levage optimal de voitures.*

Versiones con **dos brazos largos de 3 extensiones y dos de 4 extensiones**, por el levantamiento también de turismos.

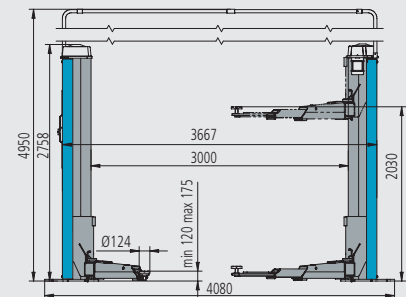

KPN 255LIKT

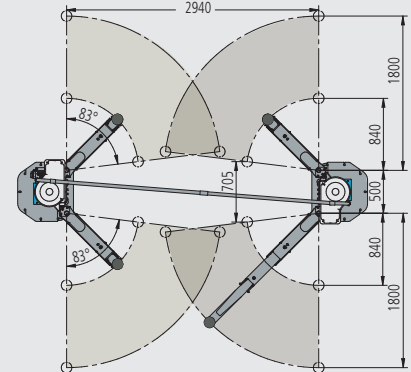

KPN 255LIKTA

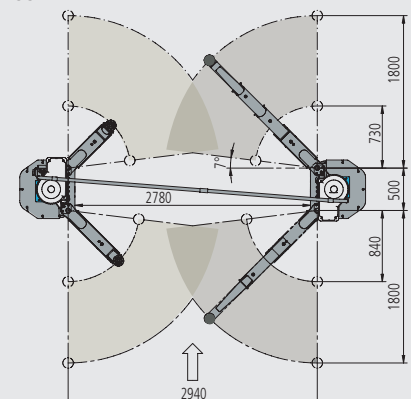

EXTRA LONG WHEEL BASE

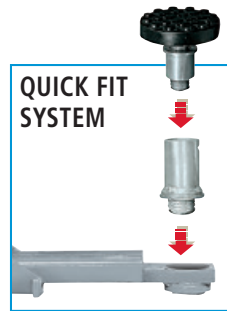

QUICK FIT SYSTEM

ARMS ON ROLLERS

I bracci scorrono su rulli montati su molle: permettono di sfilarli agevolmente e scompaiono sotto carico.

The arms' extensions slide on spring-mounted rollers, allowing easy use and a steady load.

Die Arme laufen auf Rollen, die auf Federn montiert sind: diese erleichtern das Ausziehen der Arme und schwinden unter Last.

Les rallonges des bras se déplacent sur des rouleaux montés sur ressorts, permettant un réglage facile - ces rouleaux se dégagent sous la charge.

Los brazos corren sobre rodillos montados encima de muelles: facilitan sus extensiones y desaparecen bajo carga.

OPTIONS → LIKT, LIKTA

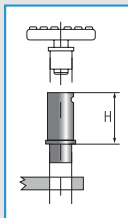

S224A3 (H=80mm)



S224A4 (H=140mm)



S370A18 (H=200mm)



For Fiat Ducato, Peugeot Boxer, Citroën Jumper

Distanziali / Spacers / Abstandstücke
 Rehausses / Espesores

OPTIONS → S224A3, S224A4, S370A18

S370A19

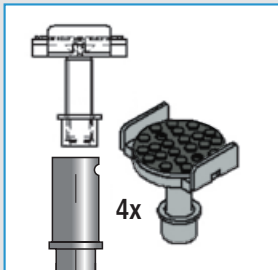

Supporti presa telaio
 Frame adapters
 Halterungen für Chassisaufnahme
 Supports prise sur chassis
 Espesores de agarre sobre chasis

S370A17

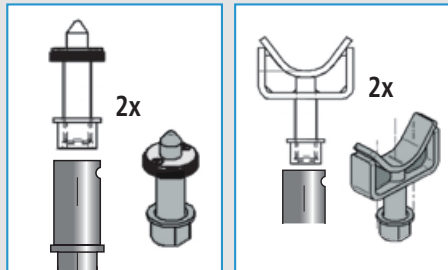

For Mercedes Sprinter, VW LT+Crafter

Supporti / Adapters / Halterungen
 Supports / Adaptadores de agarre

S5.337 A2



Supporti presa telaio / Frame adapters / Halterungen für Chassisaufnahme /
 Supports prise sur chassis / Espesores de agarre sobre chasis

SAFETY VEHICLES



Altezza minima dei tamponi di 120 mm per il caricamento asimmetrico di **auto blindate**.

*Minimum pad height of 120 mm for the asymmetric lifting of **safety vehicles**.*

Minimal Unterschwenkhöhe von 120 mm zum Anheben von **gepanzerten** Fahrzeugen.

*Hauteur mini. des tampons de 120 mm pour le chargement asymétrique de véhicules **en version blindée**.*

Altura mínima de los tacos de 120 mm para elevar vehículos como los **modelos blindados** de varios constructores.

