

# **BEST SOLUTIONS FOR MOUNTING WHEEL ALIGNMENT TARGETS AND CLAMPS**



# TYPE OF CLAMPS

Wide range of application, passenger cars and light duty trucks, standard OEM production

## TRUCK CLASSES

| CLASS AND WEIGHT                      | COVERAGE |
|---------------------------------------|----------|
| Class 1 truck 0 -6000 pounds          | Yes      |
| Class 2 truck 6,001 to 10,000 pounds  | Yes      |
| Class 3 truck 10,001 to 14,000 pounds | Yes      |
| Class 4 truck 14,001 to 16,000 pounds | Yes      |
| Class 5 truck 16,001 to 19,500 pounds | Some     |
| Class 6 truck 16,001 to 26,000 pounds | No       |
| Class 7 truck 26,001 to 33,000 pounds | No       |
| Class 8 truck 33,000 pounds and over  | No       |

- Always consider the overall weight of the vehicle
- Two wheel only alignments are possible on some vehicles
- Clamp extensions may be required for class 3 and up
  - AC200
  - AC400 extension part # EAK0305J50A

“Which is the best clamping solution for my applications?”

**(1)**

**Tire clamp**

**(2)**

**Wheel clamp**

**(3)**

**Tire clamp kit**

For use with AC 200 wheel clamps

# APPLICATION

Wide range of application, passenger cars and light duty trucks, standard OEM production

## AC 200 Wheel Clamp

## AC 400 Tire Clamp

“Which is the best clamping solution for my applications?”

- Standard OEM production, passenger cars, SUV's and light duty trucks up to 1ton
- Aftermarket tires and wheels
- Powder coated and or painted wheels use AC200 with EAK0268J63A kit
- Carbon fiber wheels use AC200 with EAK0268J63A kit (minimum wheel surface contact)
- All aspect ratios
- Standard OEM production, passenger cars, SUV's and light duty trucks up to 1ton
- Aftermarket tires and wheels with a tire aspect ratio of 55 or less
- Ideal for UHP and run-flat tires
- Ideal for carbon fiber wheels (no wheel surface contact)
- Ideal for quick alignment check

# IMPROVE PERFORMANCE

The AC400 is a highly precise measuring device and is sensitive to wheel and tire position

## AC 400 Tire Clamp

“In some cases, the tire is a flexible membrane”



- Customer wants to use AC400 clamps on pick up trucks with high aspect ratio tires, not a problem, here is the procedure and solution for that:
- Perform a new compensation after a post elevated mode adjustment when using the AC400 on a high aspect ratio tire (60 and up), off-road and mudder tires
- Never use the tire and wheel to steer for caster measurement or other measurements, always steer the front wheels using the steering wheel

# **(1) AC400 TIRE CLAMP**



Fast and easy to use, the AC400 Touchless Alignment Wheel Clamp provides secure clamping without touching the rim.



# TIRE CLAMP

For use on steel, alloy, and carbon fiber wheels with tires that have an aspect ratio of 55 or less.

AC 400 wheel clamps mount directly to the tire and do not contact the wheel's surface at any point.

AC400 clamps were designed for speed and ease of use.

They are constructed of magnesium and weight approximately 7lbs.

AC 400 self centering tire clamp



# DUALLY ADAPTERS

AC 400 clamp dually adapters (EAK0305J50A)

Extension paws for AC 400 clamps for usage on the front wheels dual rear wheel vehicles and 4X4

4X4 adapters are mounted on the front clamps to provide additional clearance between the wheel's hub and the clamp itself.

No additional adapters required for the rear wheels

Extensions provide additional clearance on 4X4 vehicles





# TIRE CLAMP

Wider paws are required for mudder or off road applications and 4X4 with high positive offset wheel centers.

4X4 adapters are mounted on the front clamps to provide additional clearance between the wheel's hub and the clamp itself.

Use two sets of dually wheel adapters on off-road and mudder types of tires

AC 400 clamp dually adapters (EAK0305J50A)



1 set = 6 paws for 2 AC400 clamps

High void-to-rubber ratio on the outside of the tire delivers extreme off-road traction. This design requires the wider tire paws or dually adapters part # EAK0305J50A.

Two sets one for both front clamps and one set for both rear clamps

Aggressive open shoulder design features scalloped tread blocks for greater traction and mobility on soft surfaces. Recommend AC200 wheel clamps and clamp from the inside of rim

Narrow rim lip  
Makes it difficult to insert rim claws  
Easier and faster to use AC200 clamps





# TIRE CLAMP

Wide range of application, passenger cars and light duty trucks, standard OEM production

## TRUCK CLASSES

### CLASS AND WEIGHT

### COVERAGE

Class 1 truck 0 -6000 pounds

Yes

Class 2 truck 6,001 to 10,000 pounds

Yes

Class 3 truck 10,001 to 14,000 pounds

Yes

Class 4 truck 14,001 to 16,000 pounds

Yes

Class 5 truck 16,001 to 19,500 pounds

Some

Class 6 truck 16,001 to 26,000 pounds

No

Class 7 truck 26,001 to 33,000 pounds

No

Class 8 truck 33,000 pounds and over

No

- Always consider the overall weight of the vehicle
- Two wheel only alignments are possible on some vehicles
- Clamp extensions may be required for class 3 and up
  - AC200 extension part # EAK0289J62B
  - AC400 extension part # EAK0305J50A

AC 400 clamp range



# (2) AC 200 WHEEL CLAMP



| Description                                                                                                | Part Number |
|------------------------------------------------------------------------------------------------------------|-------------|
| <b>Wheel Clamp Kit – Conventional</b><br>2 CCD clamps and bungee cords, boxed with rim claws               | EAK0268J42A |
| <b>Wheel Clamp – Conventional (Service)</b><br>1 CCD clamp and bungee cord, boxed with rim claws           | EAK0268J55A |
| <b>Rim Clamp / Target Set</b><br>4 clamps with targets mounted and bungee cords, boxed with rim claws      | EAK0268J52A |
| <b>Wheel Clamp Kit – Imaging</b><br>2 front & 2 rear imaging clamps and bungee cords, boxed with rim claws | EAK0268J64A |
| <b>Wheel Clamp – Imaging, Front (Service)</b><br>1 front clamps and bungee cords, boxed with rim claws     | EAK0268J56A |
| <b>Wheel Clamp – Imaging, Rear (Service)</b><br>1 rear clamp and bungee cord, boxed with rim claws         | EAK0268J57A |
| <b>Extension Kit – Single Clamp</b><br>4 extensions for 1 clamp                                            | EAK0268J40A |
| <b>Extension Kit – Complete Aligner</b><br>16 extensions for 4 clamps or 1 aligner                         | EAK0268J62A |
| <b>Rim Claw Kit</b><br>4 dual-end rim claws for 1 clamp                                                    | EAK0268J41A |
| <b>O-Ring Kit</b><br>32 o-rings to service 4 clamps                                                        | EAK0268J51A |
| <b>Tire Clamp Kit</b><br>4 tire clamps and 2 sets of claw sleeves                                          | EAK0268J63A |

# WHEEL CLAMP

AC 200 clamp with single sided claws

For use on steel and alloy wheels with high aspect ratio tires such as 65 series and off-road "mudder" tires such as a MAXXIS MT-764 BUCKSHOT II 27/8.50R-14L

AC 200 wheel clamps mount directly to the wheel's outer rim edge and provide a positive engagement on heavier vehicles.

Great for wheels off and elevated adjustment procedures.

Optional double side claw for ease of mounting over hub caps part# EAK0268J41B



Honda hubcaps are held in place using the wheel lug nuts making it difficult and cumbersome to remove to mount wheel alignment clamps





# AC 200 RANGE

AC 200 clamp extensions  
EAK0268J62A

Add more range to the AC200  
clamp

Fully extended up to 29" (28" rim)  
Fully retracted 17"



EAK0268J62A  
1 kit contains 16 extensions 4  
four each clamp

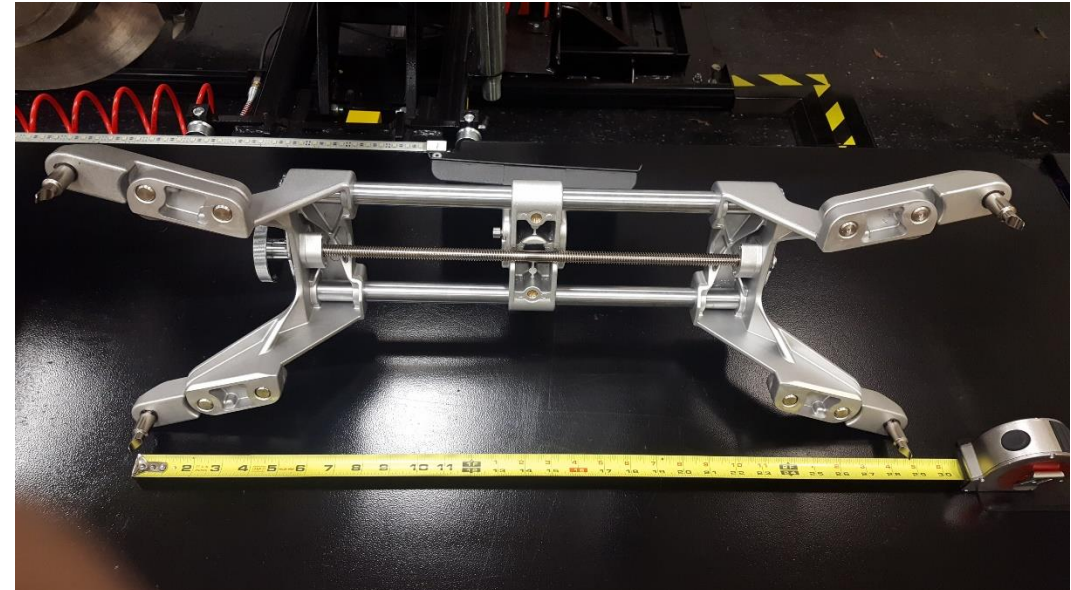
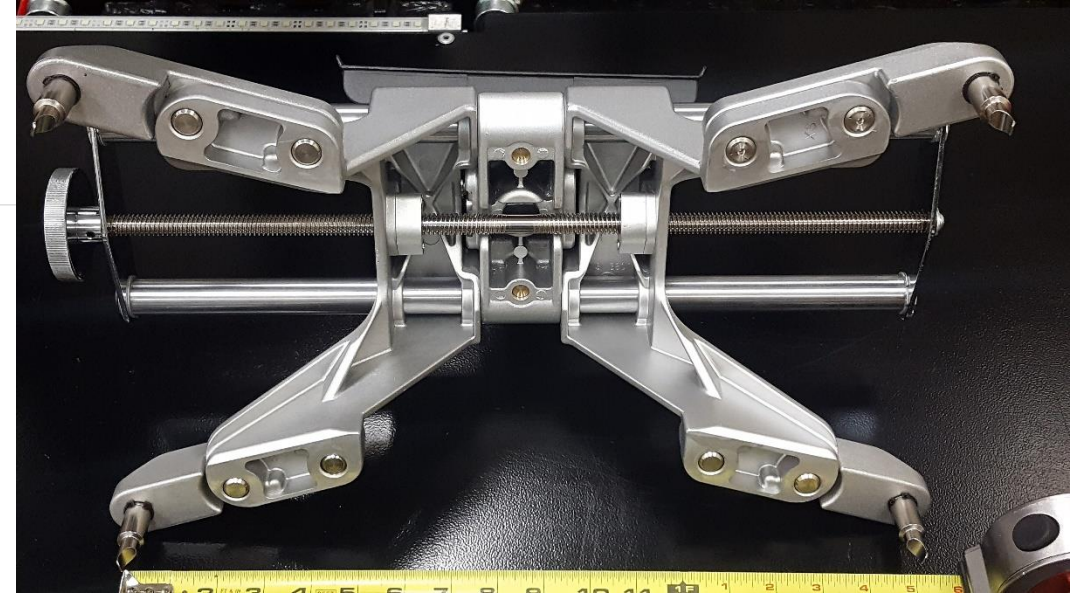

# BEAD LOCK WHEELS

AC 200 clamp with single side claws

For Beadlock style wheels, use AC200, reverse the claws, and clamp from the inside

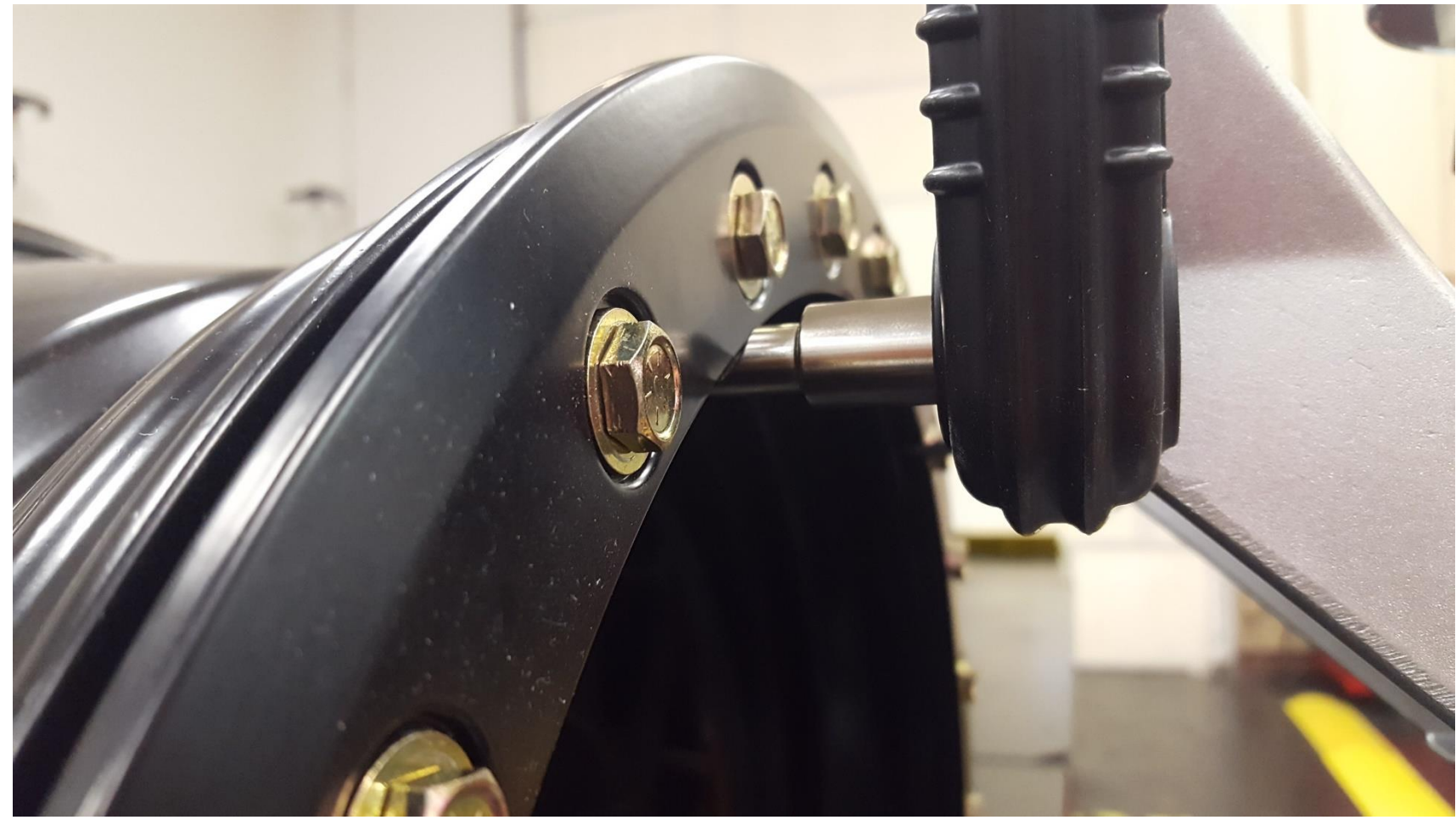
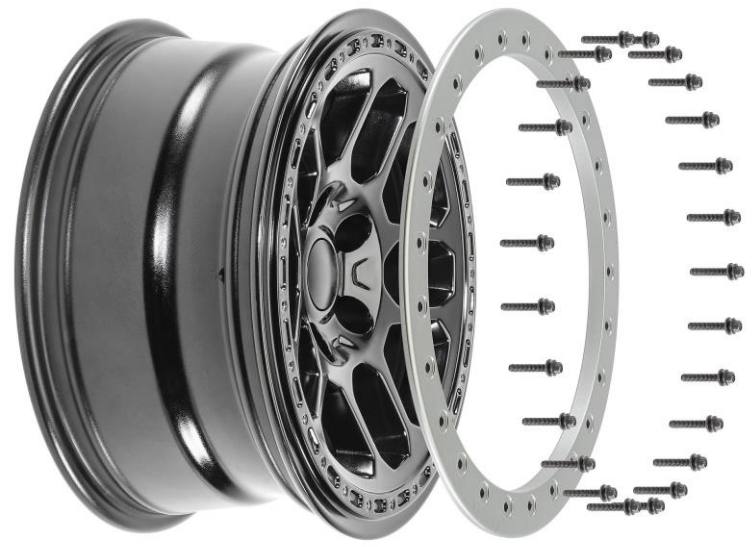



# WHEELS OFF

Wheel off mounting

Can be used for wheels off  
ADJUSTMENT ONLY procedures  
and mounted directly to the disk in  
most cases. In some cases, wheels  
off adapters may be required

(**EAK0222J83B** for both the AC200  
and AC 400 style of clamps)

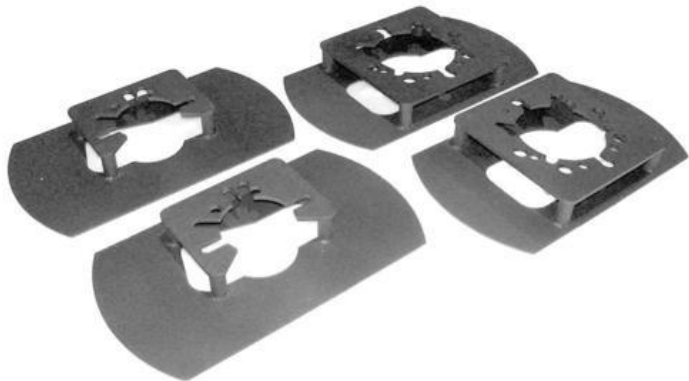

Mount wheel clamp to the  
brake disk without the use of  
special adapters for  
ADJUSTMENT ONLY

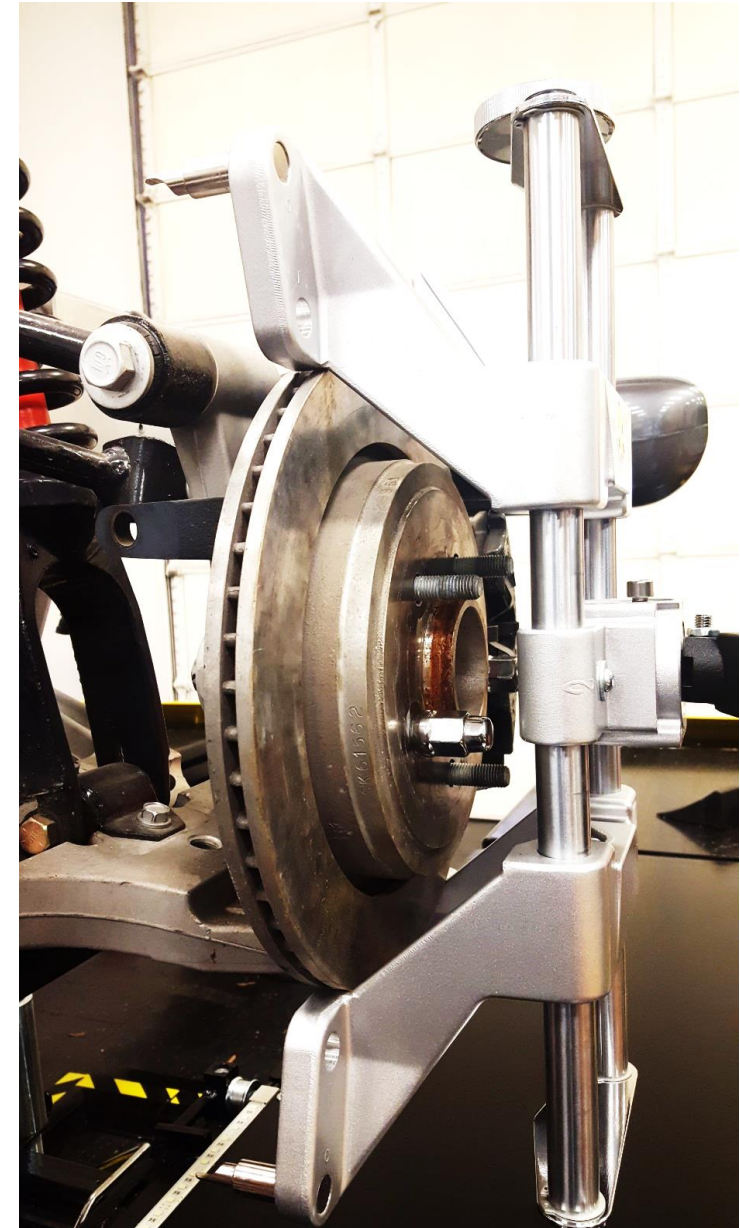



# DUALY ADAPTERS

Dually adapters **EAK0289J62B**  
Dual rear wheel vehicles, 4X4, and motorhomes

AC 200\700 2" clamp extension kit,  
moves the clamp out allowing  
clearance for 4X4 hubs

AC 200\700 2" extensions

4 adapters per clamp with mounting  
hardware

EAK0289J62B contains sixteen adapters  
and mounting hardware to fit four clamps

Can be used on the front wheel of dual  
wheel vehicles to clear the hub

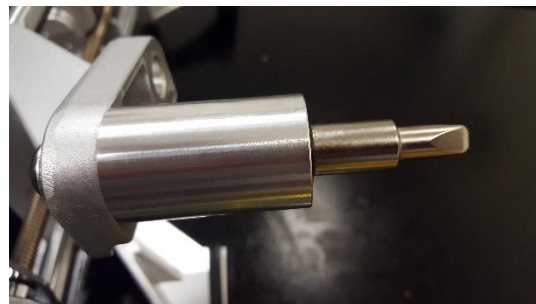
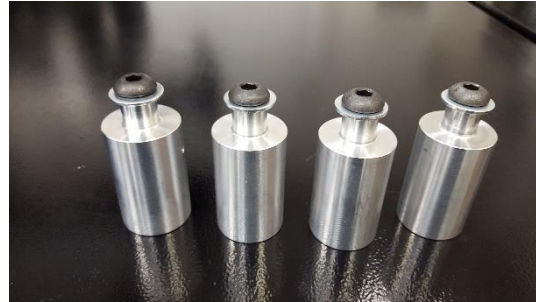



**(3) TIRE CLAMP  
KIT**

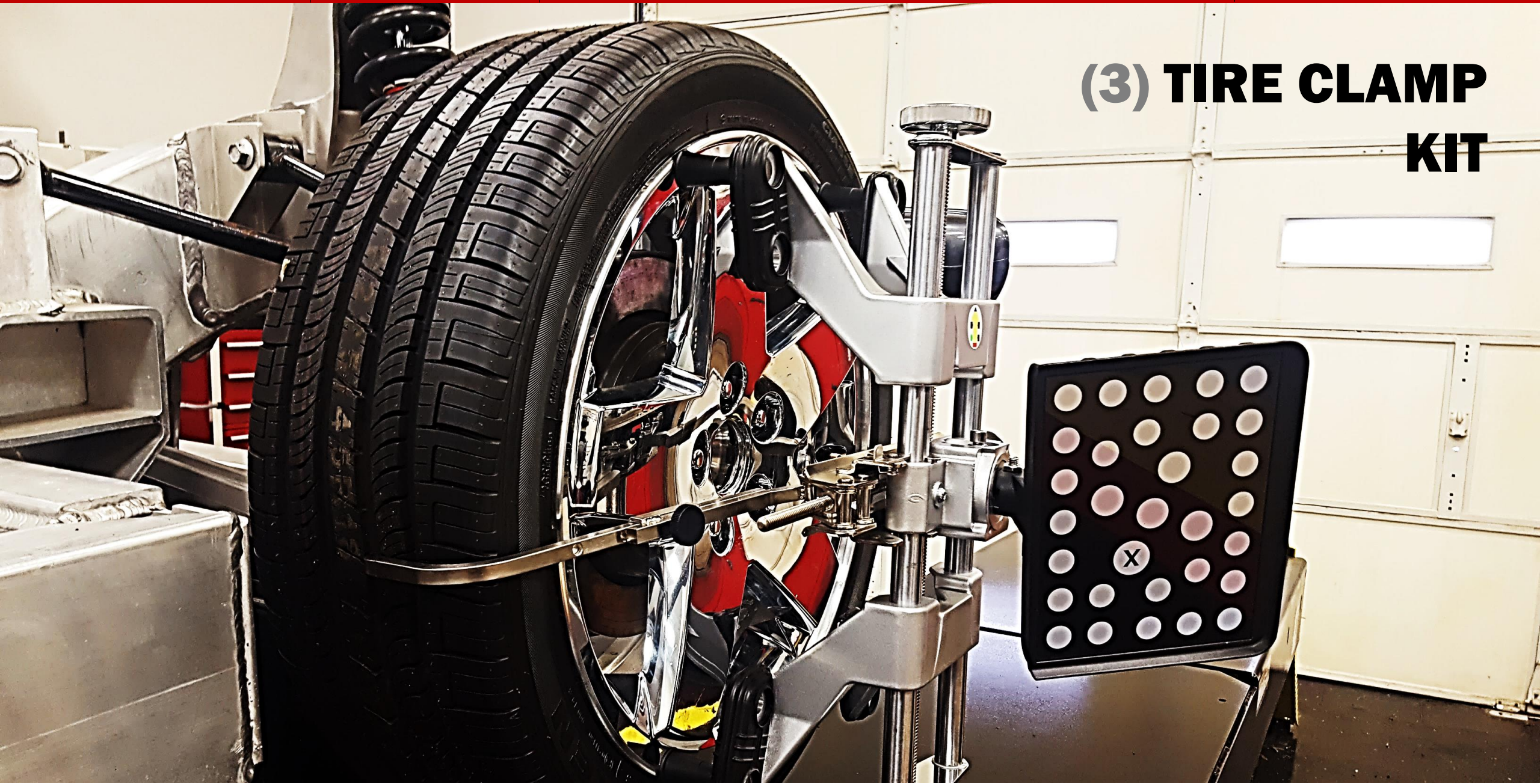



# HYBRID WHEEL CLAMP KIT

**EAK0268J63A**

Consist of four tire grabbers and 32 plastic adapters

This clamping system offers a solution for customers with AC200 clamps that work on custom wheels



Tire Clamp Kit

Kit P/N: EAK0268J63A  
Clamps per kit: 4  
Sleeves per kit: 32  
Kits per aligner: 1

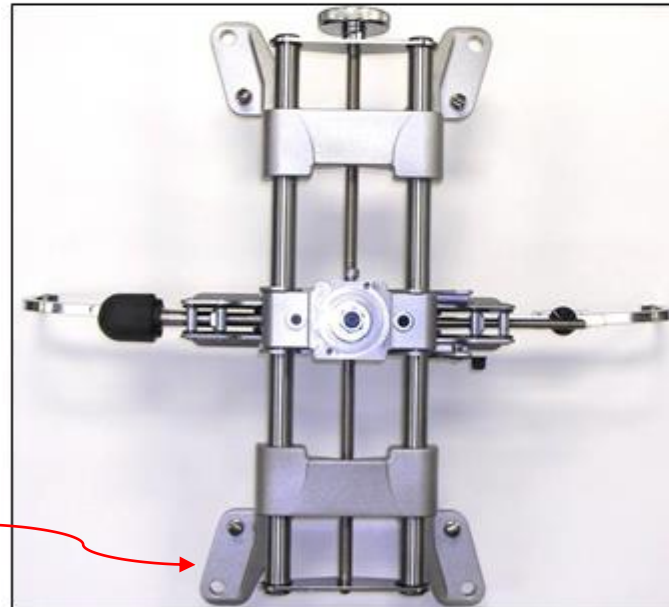

AC 200 CLAMP NOT  
INCLUDED IN THE KIT





# HYBRID CLAMP

Easy set up, simply unlock and slide over the center clamp hub and release the lock.

AC 200 clamp with tire gabbers and rim protectors

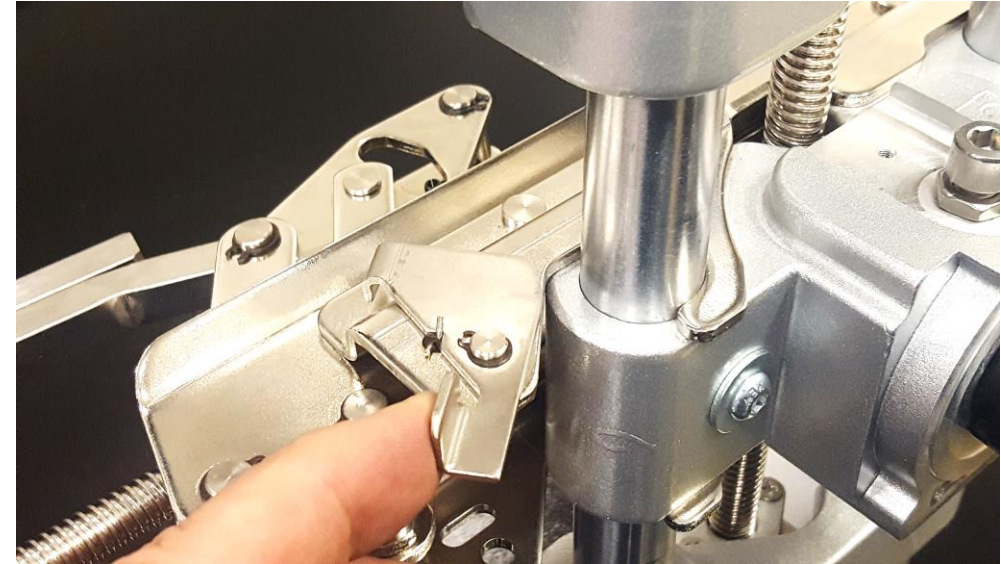

Slide over until the lock is fully engaged

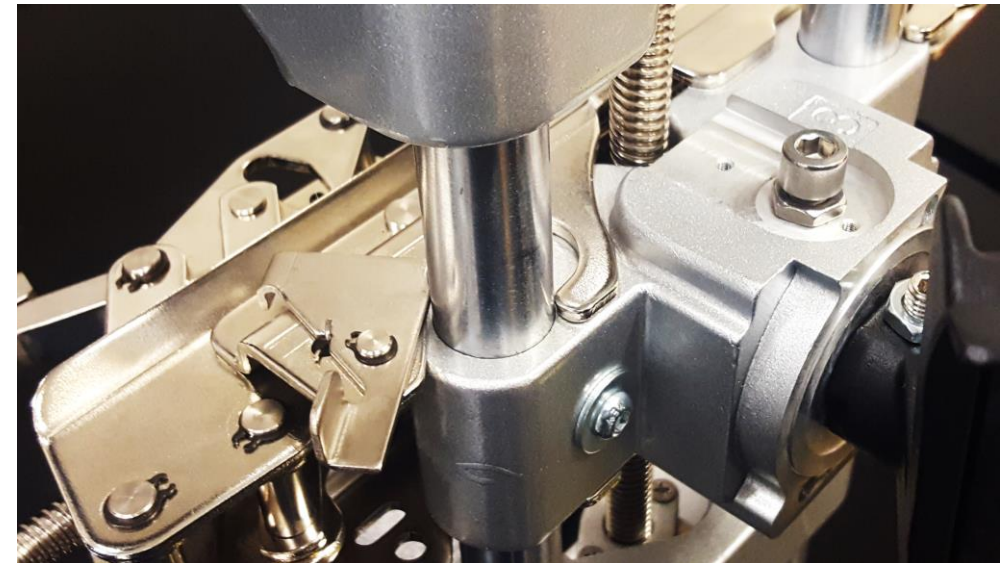

# HYBRID CLAMP

For use on alloy and steel painted or powder coated wheels.

Work well on high and low aspect ratio tires and mudder tire and:

- Steel wheel
- Alloy wheel
- Carbon fiber wheel
- Bead lock wheels

AC 200 clamp with tire grabbers and rim protectors

Plastic protectors  
4 per clamp

Tire grabber

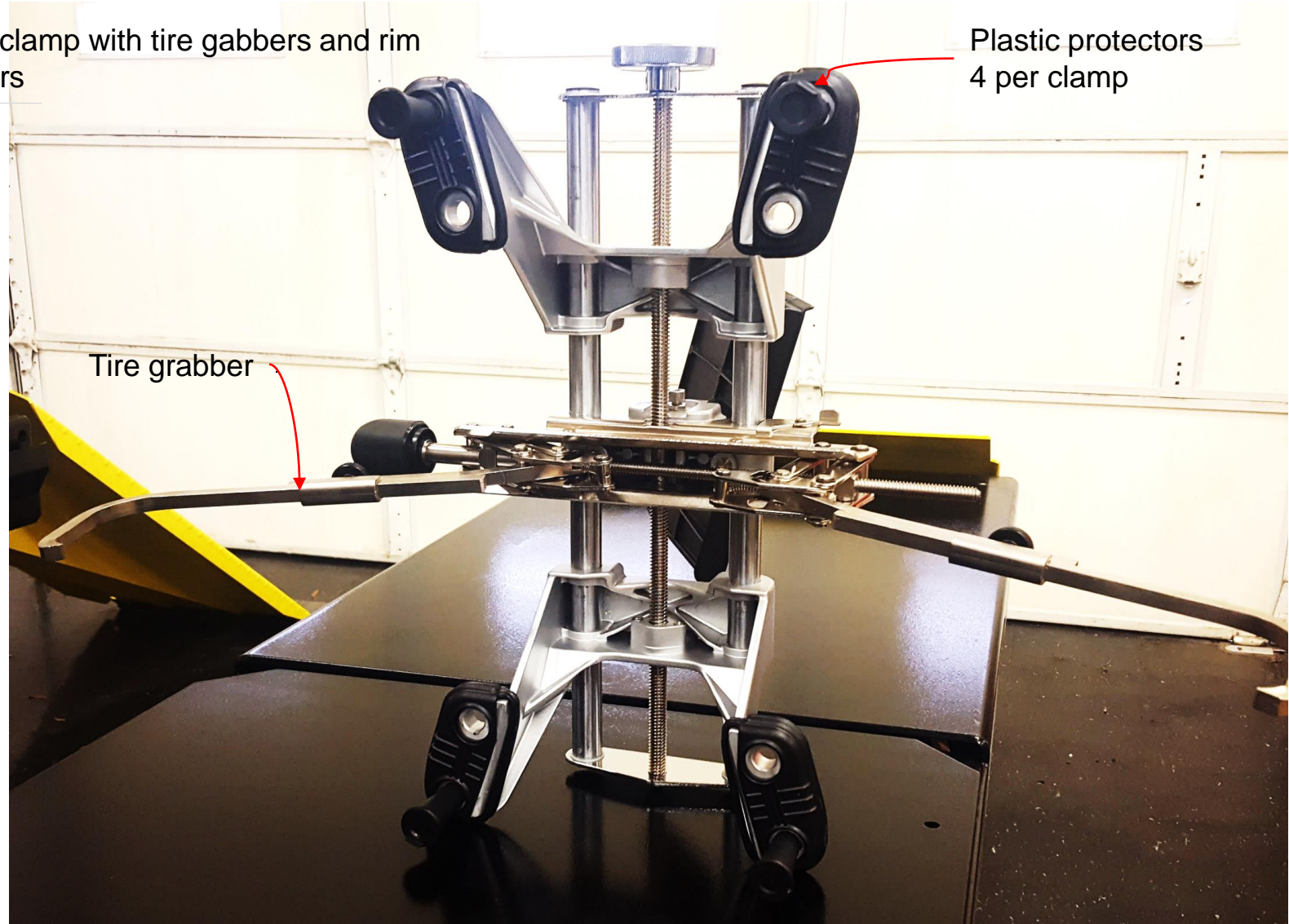



# HYBRID CLAMP

Small plastic protectors slide over the wheel clamp's claw

- Fast set up
- Rim protection



AC 200 clamp with tire gabbers and rim protectors





# HYBRID CLAMP

AC 200 clamp with tire gabbers and rim protectors

The plastic wheel protectors rests against the rim's edge to position the clamp on the wheel.

Allows for AC200 use on custom, painted, powder coated or clad wheels.

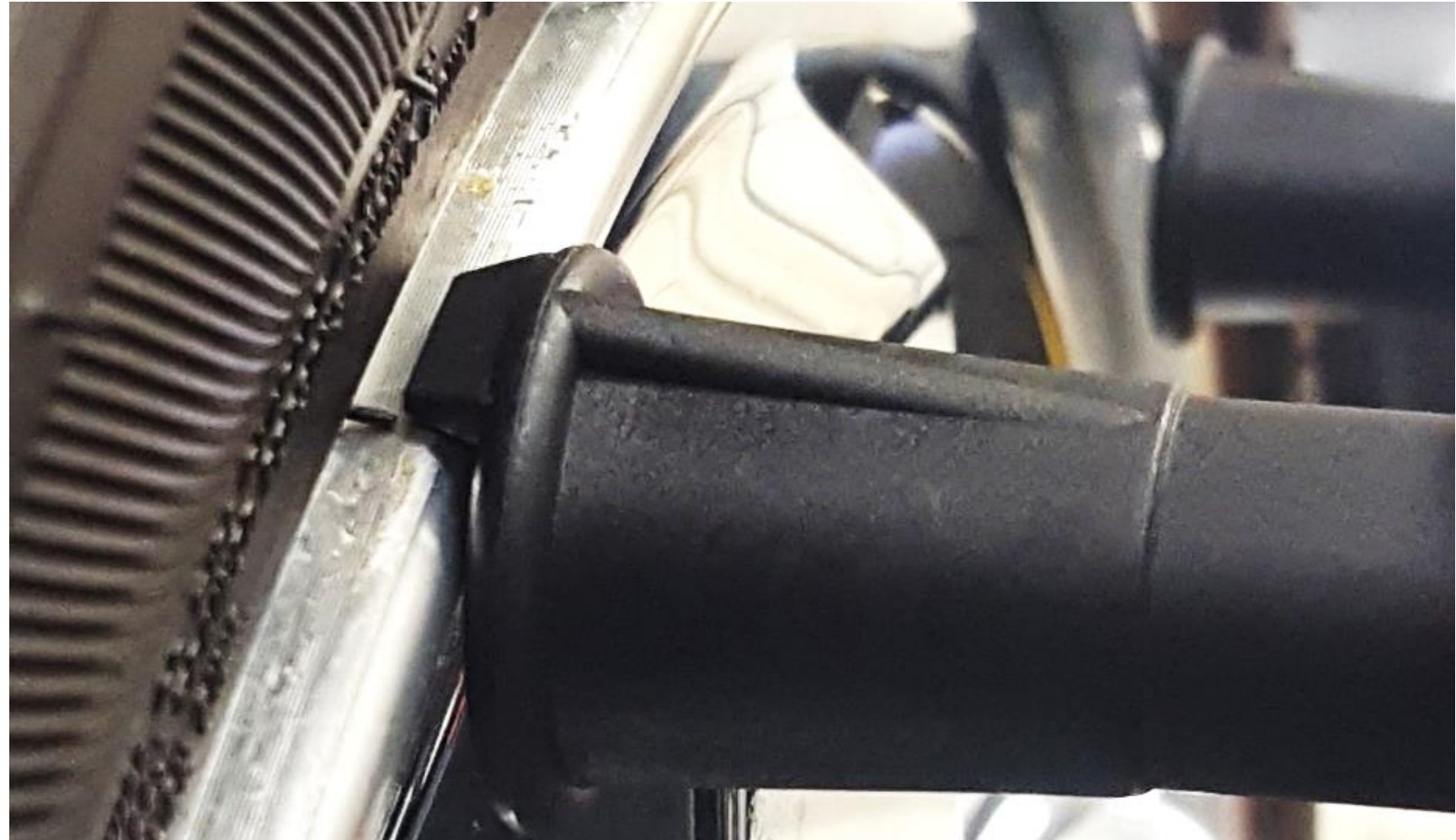

# HYBRID CLAMP

Fully mounted clamp with plastic rim protectors and tire grabber

- Minimum wheel contact
- No steel-to-steel contact
- Universal application

AC 200 clamp with tire gabbers and rim protectors

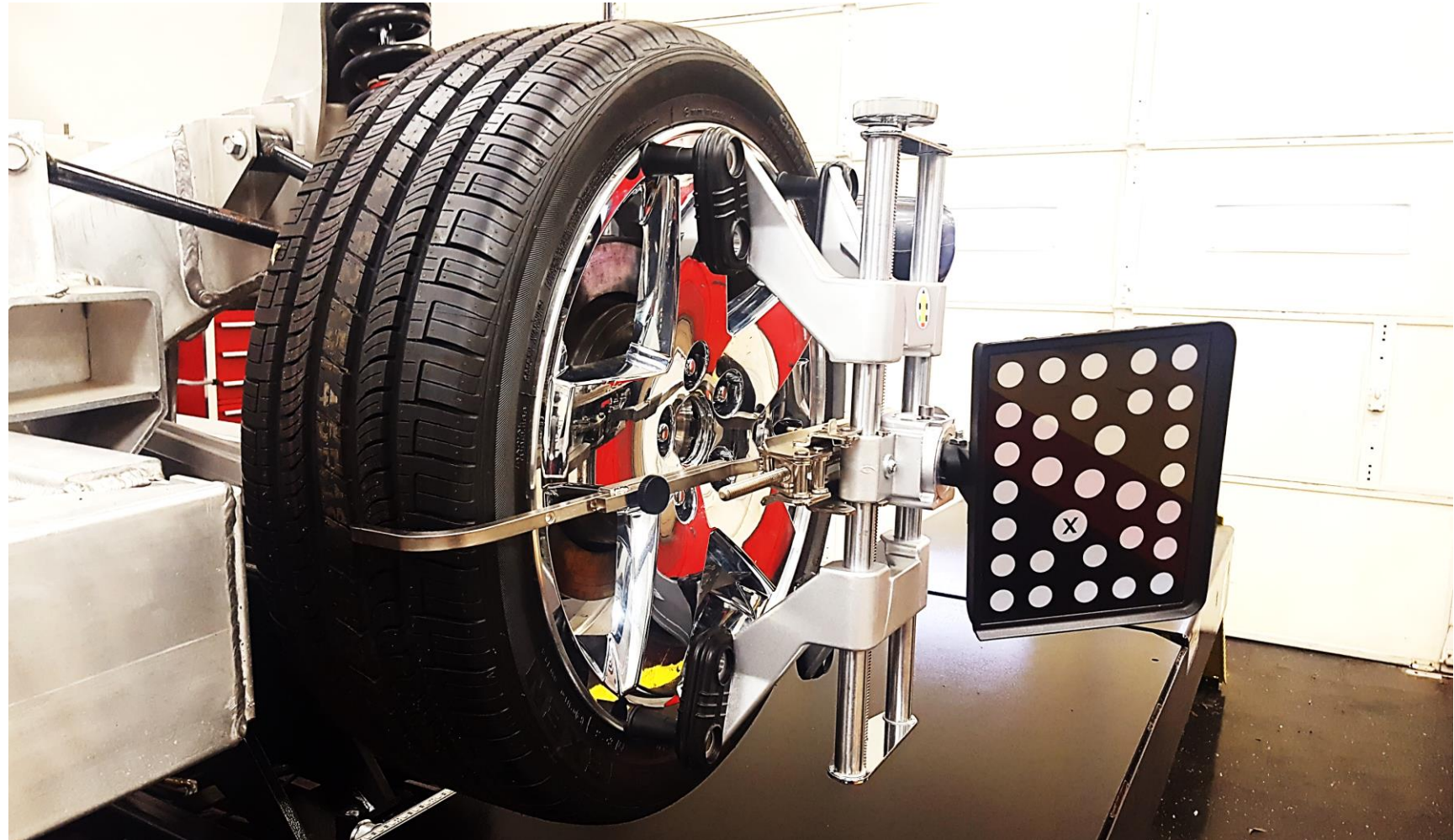



# QUICK CLAMP

This type of clamp is good for fast mounting on a wheel however consider the following:

- The clamp does not center itself on the wheel (1)
- The clamp to wheel contact area rubber o ring is much larger than the contact area of the four claws on one clamp (2)
- The clamp has a tendency to creep down when attempting to perform an adjustment on the strut for example (3)
- In some cases, the technician places the clamp on the ground after an alignment. Dirt and contaminants from the ground transfers to the protective rubber on the clamp's rim. Photo #4 show a scratched clad covered wheel. The scratch occurred from mounting a clamp previously placed on the floor without cleaning the rubber protector.

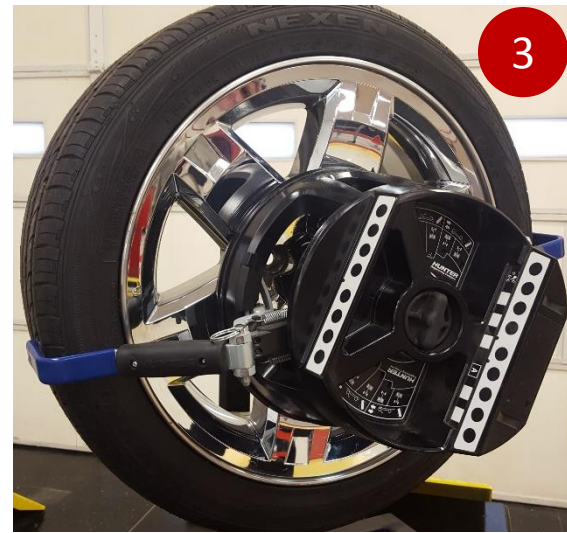
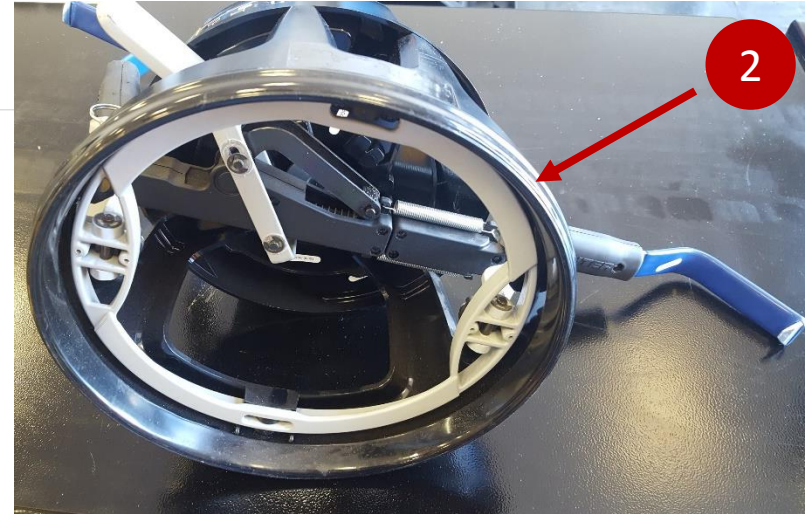

## APPLICATION CHART

| Model | Clamp | Description                                                            | Aspect Ratio | Tire Type                             | AC200 2 SIDED CLAWS | AC 400 DUALY ADAPTERS                       |        | 28" AC200 CLAMP EXTENSIONS | HYBRID CLAMP ADAPTERS | 2" AC200 Claw Extension |
|-------|-------|------------------------------------------------------------------------|--------------|---------------------------------------|---------------------|---------------------------------------------|--------|----------------------------|-----------------------|-------------------------|
|       |       |                                                                        |              |                                       | EAK0268J41B         | EAK0305J50A<br>Dual wheel only Mudder tires |        | EAK0268J62A                | EAK0268J63A           | EAK0289J62B             |
| V3300 | AC200 | Passenger cars and light duty trucks (up to 1ton) standard OEM product | All          | Standard UHP Runflat OffRoad (Mudder) | 4 Kits              |                                             |        | 1 Kit                      | 1 Kit                 | 1 Kit                   |
|       | AC400 | Passenger cars and light duty trucks (up to 1ton) standard OEM product | 55 and lower | Standard UHP Runflat                  |                     | 1 Kit                                       | 2 Kits |                            |                       |                         |
| V2100 | AC200 | Passenger cars and light duty trucks (up to 1ton) standard OEM product | All          | Standard UHP Runflat OffRoad (Mudder) | 4 Kits              |                                             |        | 1 Kit                      | 1 Kit                 | 1 Kit                   |
| V1200 | AC200 | Passenger cars and light duty trucks (up to 1ton) standard OEM product | All          | Standard UHP Runflat OffRoad (Mudder) | 4 Kits              |                                             |        | 1 Kit                      | 1 Kit                 | 1 Kit                   |
| V3400 | AC200 | Passenger cars and light duty trucks (up to 1ton) standard OEM product | All          | Standard UHP Runflat OffRoad (Mudder) | 4 Kits              |                                             |        | 1 Kit                      | 1 Kit                 | 1 Kit                   |
|       | AC400 | Passenger cars and light duty trucks (up to 1ton) standard OEM product | 55 and lower | Standard UHP Runflat                  |                     | 1 Kit                                       | 2 Kits |                            |                       |                         |
| V2400 | AC200 | Passenger cars and light duty trucks (up to 1ton) standard OEM product | All          | Standard UHP Runflat OffRoad (Mudder) | 4 Kits              |                                             |        | 1 Kit                      | 1 Kit                 | 1 Kit                   |
|       | AC400 | Passenger cars and light duty trucks (up to 1ton) standard OEM product | 55 and lower | Standard UHP Runflat                  |                     | 1 Kit                                       | 2 Kits |                            |                       |                         |
| V2300 | AC200 | Passenger cars and light duty trucks (up to 1ton) standard OEM product | All          | Standard UHP Runflat OffRoad (Mudder) | 4 Kits              |                                             |        | 1 Kit                      | 1 Kit                 | 1 Kit                   |
|       | AC400 | Passenger cars and light duty trucks (up to 1ton) standard OEM product | 55 and lower | Standard UHP Runflat                  |                     | 1 Kit                                       | 2 Kits |                            |                       |                         |
| V2200 | AC200 | Passenger cars and light duty trucks (up to 1ton) standard OEM product | All          | Standard UHP Runflat OffRoad (Mudder) | 4 Kits              |                                             |        | 1 Kit                      | 1 Kit                 | 1 Kit                   |
| V3450 | AC400 | Passenger cars and light duty trucks (up to 1ton) standard OEM product | All          | All tires                             |                     | 1 Kit                                       | 2 Kits |                            |                       |                         |

**EAK0268J41B** Double side claw kit for AC 200. Allows AC200 clamp mounting on wheels that have the wheel cover extend all the way to edge of the rim and are retained in place by the lug nuts. 1 kit contains 4 claws | 1 kit per clamp

**EAK0305J50A** AC 400 tire clamp dual wheel adapter kit, Provide additional clearance for 4X4 hubs on the front. Contains 6 extension paws for 2 clamps

**EAK0268J62A** AC 200\700 wheel clamp extension. Extended the clamping range to 28"

Use 2 kits when dealing with off road or mudder type tires

**EAK0268J63A** AC 200\700 tire grabber kit. Contains 4 tire grabbers a with an assortment of rim claw plastic protectors. Facilitates mounting of AC 200 clamps on painted or powder coated wheels

**EAK0289J62B** AC 200\700 2" extension kit. Provide additional clearance for the front 4X4 hubs