

# Butler

# Logic

## OPEN FRONT

LOGIC50A  
OF  
LOGIC50A  
OFT

LIFTS

 **PONTI 4 COLONNE CON SOLLEVATORE INTEGRATO**

 **4-POST LIFTS WITH WHEEL FREE LIFT**

 **4-SÄULEN-HEBEBÜHNEN MIT RADFREIHEBER**

 **PONTS 4 COLONNES AVEC LEVAGE AUXILIAIRE**

 **4 COLUMNAS CON DOBLE ELEVACIÓN**

Versioni per misurazione assetto ruote  
*Wheel alignment versions*  
Versionen für die Achsvermessung  
*Versions pour contrôle de géométrie*  
Versiones alineado de direccion

### LOGIC50A OF / 5000 kg

Pedane per assetto totale extralunghe con sedi anteriori per piatti rotanti e piani oscillanti posteriori.

*Extra-long platforms for total wheel alignment with front turning plates locations and rear slip plates.*

Extra lange Fahrmaschinen für die gesamte Achsvermessung, vorne mit Aussparungen für Drehplatten und hinten mit Schwingplatten

*Chemins de roulement pour géométrie totale extralongs avec logements avant pour plateaux pivotants et plans mobiles arrière.*

Plataformas para alineación total extra-largas con asientos para platos giratorios delanteros y platos oscilantes traseros

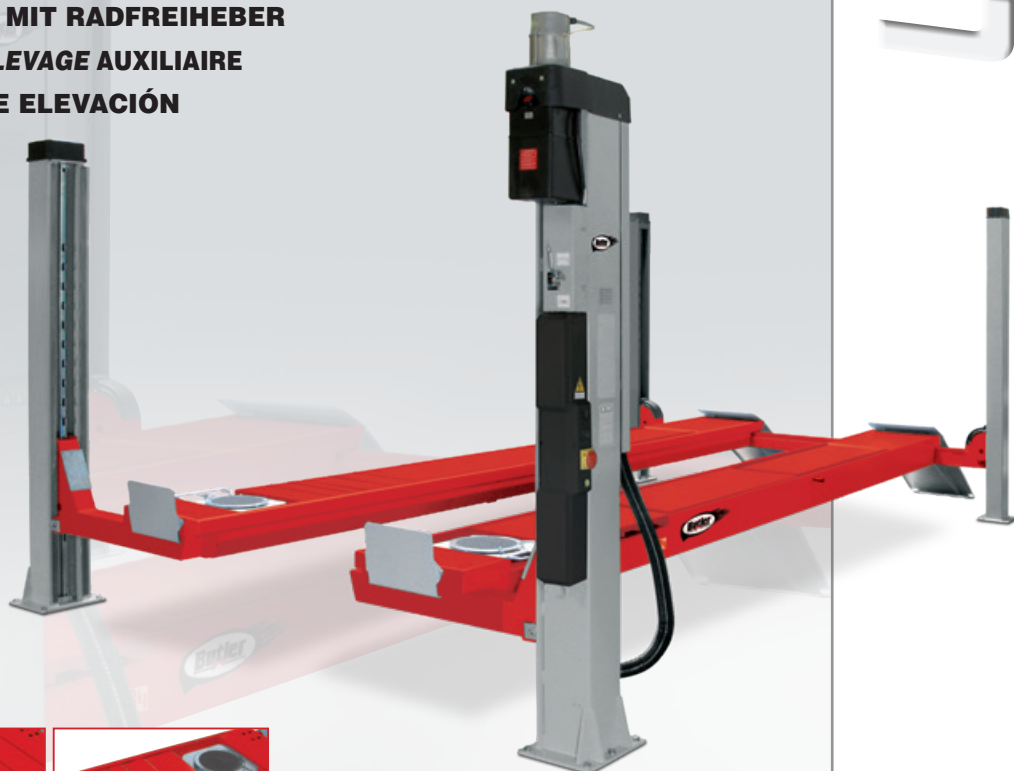

### Multi-Position



### Open Front

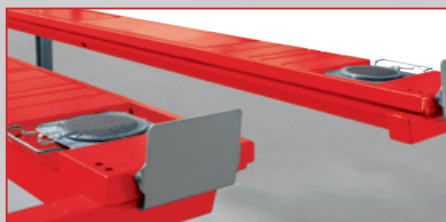

Accesso totale alla zona di lavoro  
*Full access to the working area*  
Komplett freier Zugang im Arbeitsbereich  
*Accès complètement libre à la zone de travail*  
Acceso total al área de trabajo

**Piani oscillanti posteriori** a bassissimo attrito, con bloccaggio manuale in posizione centrata e movimenti di oscillazione angolare e trasversale in entrambe le direzioni.

**Low-friction rear slip plates.** They can be manually locked in the central position. Transverse and angular movements in both directions.

**Hintere Schiebepplatten** mit niedrigem Reibungsgrad, manueller Blockierung in zentrierter Position und Schwingbewegungen über Eck- und Querlaufend in beide Richtungen.

**Plans mobiles arrière** à très faible frottement, avec blocage manuel en position centrée et mouvement angulaire et transversal dans les deux directions.

**Platos traseros** con bajo nivel de fricción, bloqueo manual en posición centrada y movimientos de oscilación angular y transversal en ambas direcciones.

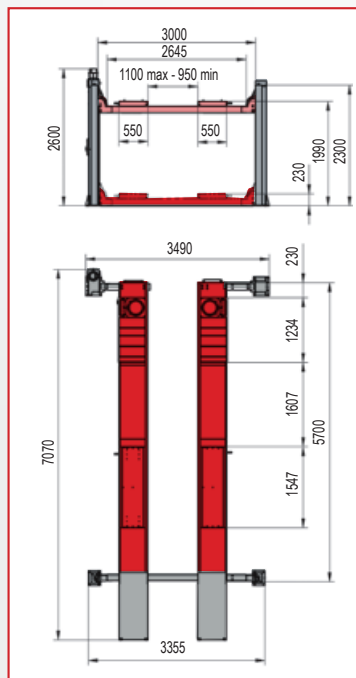

# OPEN FRONT LIFT TABLE



Selettore per sollevamento ponte principale o sollevatore integrato.

Switch to operate main lift of wheel free lift

Schalthebel für Haupthebebühne bzw. Radfreiheber.

Selecteur pour actionnement du pont ou du levage auxiliaire

Selector para elevación del elevador principal o de la doble elevación

Pulsante di salita

Lifting button

Hebeknopf

Commande de montée

Pulsador de subida

Pulsante di discesa

Lowering button

Senkknopf

Commande de descente

Pulsador de bajada

Interruttore generale

Main switch

Hauptschalter

Interrupteur principal

Interruptor general

Pulsante di parcheggio per assetto ruote

Parking button for wheel alignment

Parkknopf für Achsmessstellung

Commande de positionnement sur crémaillière

pour contrôle de géométrie

Pulsador de parking para alineado de ruedas

(LOGIC50OFT)

Struttura rinforzata

Extra strength structure

Sehr robuste Struktur

Structure renforcée

Estructura reforzada

## Lift Table



### LOGIC50A OFT / 5000 kg

**Pedane per assetto ruote**, con sedi anteriori per piattori rotanti e piani oscillanti posteriori.

**Platforms for total wheel alignment**, with front turning plates recesses and rear slip plates.

**Fahrschienen für die Achsvermessung**, vorne mit Sitzen für Drehteller und hinten mit Schiebepfatten.

**Chemins de roulement pour géométrie**, avec logements avant pour plateaux pivotants et plans mobiles arrière.

**Plataformas para alineación**, con asientos para platos giratorios delanteros y platos oscilantes traseros

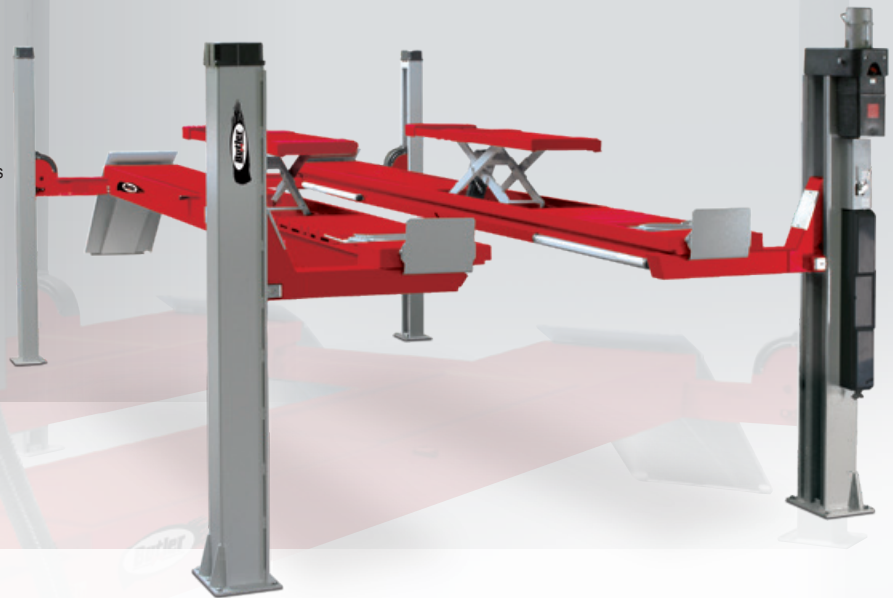
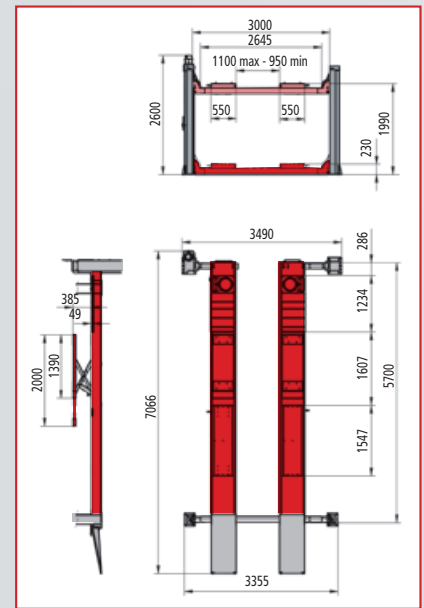

## OPTIONS

S505A1 H= 200 mm

S505A5 H= 120 mm

S505A9 H= 60 mm (standard)

S505A6 H= 40 mm

S505A7 H= 20 mm

Set Tamponi - Set of pads - Satz Klötze - Tampons - Juego de tacos (4 x kit)

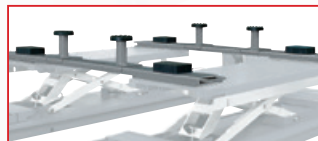

S505A2 (2 x kit)  
Traverse / Cross members  
Querstreben / Traverses / Traviesas



Rampe extralunghe  
Long run up ramps  
Lange Auffahrampen  
Rampes longues  
Rampas larga

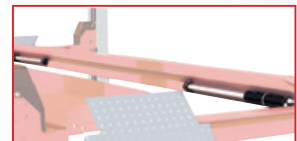

Impianto di illuminazione  
Lighting kit  
Beleuchtung  
Système d'éclairage  
Instalación de alumbrado

# Butler

Engineering and Marketing S.p.A. a.s.u.  
Via dell'Ecologia 6 - 42047 Rolo (RE)  
Ph. +39-0522-647911 - Fax +39-0522-649760  
www.butler.it - info@butler.it

A DOVER COMPANY

DBD17U (02)

Le caratteristiche tecniche e gli allestimenti presentati in questo prospetto possono subire variazioni. Le immagini riprodotte non sono vincolanti.  
Technical data and composition presented in this catalogue may vary. Pictures reproduced are only indicative.  
Die techn. Daten und die Ausrüstungen, die in diesem Prospekt enthalten sind, können Änderungen erfahren. Deshalb sind die Abbildungen unverbindlich.  
Les caractéristiques techniques et les compositions présentées dans ce prospectus peuvent subir des variations. Les images reproduites n'ont qu'une valeur indicative.  
Las características técnicas y las composiciones ilustradas en este folleto pueden sufrir variaciones. Las imágenes propuestas son solamente indicativas.