





MADE IN
ITALY

Butler

BU TD2.0WIFI

ALIGNMENT NO-LIMIT

**TD2.0
WIFI**

-  **ASSETTO RUOTE SU TABLET**
-  **TABLET CONTROLLED
WHEEL ALIGNER**
-  **TABLET GESTEUERTES
ACHSMESSGERÄT**
-  **GEOMETRIE SUR TABLETTE**
-  **ALINEADOR SU TABLET**

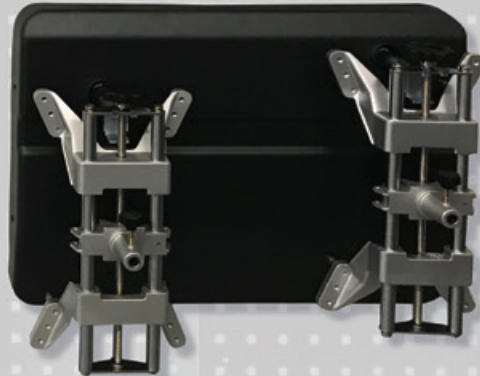
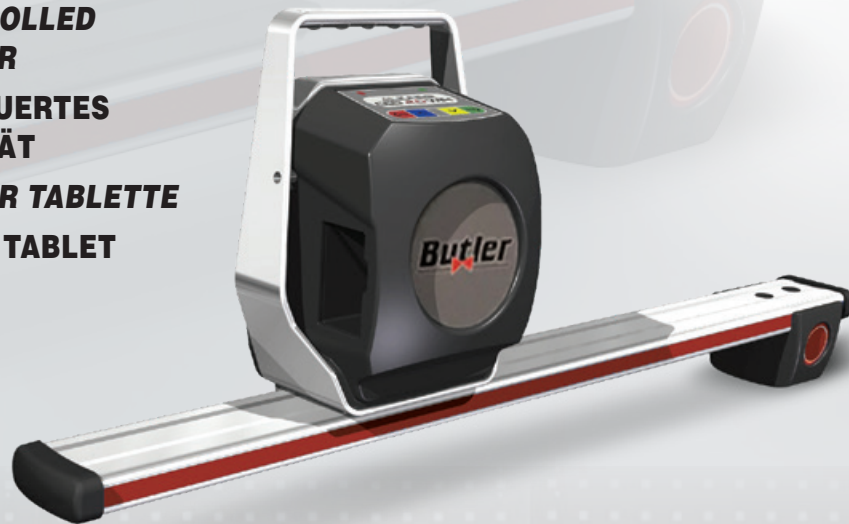

WHEEL ALIGNERS



Un nuovo concetto di assetto route CCD. Totalmente privo di PC, è utilizzabile tramite una connessione Wi-Fi da un dispositivo portatile. Alternativa high-tech alle attuali soluzioni di mercato. Riprogettazione completa delle teste di misura e nuovo supporto per le teste e le graffe.

A new concept of CCD wheel aligner. Totally PC-free will be usable through a Wi-Fi connection from a handheld device. High tech alternative to the current solutions on the market. Complete redesign of the measuring heads and new concept for the heads and clamps storage.

Ein neues Konzept von CCD-Achsmessgeräten. Ohne PC jedoch mit Wi-Fi-Verbindung wird mittels eines Tablet gesteuert. Eine Hi-Tech-Alternative zu verschiedenen Produktlösungen auf dem Markt. Komplett neues Design der Messköpfe und neues Konzept einer Ablagevorrichtung für die Messwertaufnehmer und Radklammer.

Un nouveau concept de géométrie CCD. Sans PC, utilise un dispositif portable (tablette) connecté en Wi-Fi. Une alternative High Tech à toutes les solutions présentes sur le marché. Nouvelles têtes de mesure, nouveau design, avec un concept innovant de rangement des têtes et des griffes qui limite l'encombrement dans l'atelier.

Un nuevo concepto de alineador CCD. Totalmente sin PC, se utiliza a través de la red Wi-Fi, desde un dispositivo portátil. Una alternativa altamente tecnológica a las soluciones presentes en el mercado de hoy en día. Los captadores han sido completamente rediseñados, así como su almacenamiento y el de las garras.

RAVTD2.0WIFI comprende:

- Tablet
- Kit di magneti adesivi per il tablet
- Punto di accesso Wi-Fi
- Pannelli a parete per i sensori con presa di carica USB, porta per punto di accesso e support per tablet
- Sensori 8-CCD con cuscinetti, 1 encoder e spine di ricarica rapida
- Coppia di piatti S110A7/P
- 1 premi pedale del freno
- 1 blocca del volante
- 2 paia di graffe a 4 punti STDA33EU

RAVTD2.0WIFI includes:

- Tablet
- Kit adhesiv magnets for the tablet
- Access point Wi-Fi
- Wall panels for the sensors with charge plug USB, access point port and tablet holder
- 8-CCD sensors with bearings, 1 encoder and quick charging plugs
- Pair turntables S110A7/P
- 1 brake pedal depressor
- 1 steering wheel lock
- 2 pairs of STDA33EU four point clamps

RAVTD2.0WIFI Lieferumfang:

- Tablet
- Magnethalterung für das Tablet
- Wi-Fi-Access-Point
- Wandpaneel für die Messköpfe mit USB-Ladestecker, Access-Point und Tablet-Ablage
- 8-CCD Sensoren mit kugelgelarten Bolzen, 1 Encoder und Schnellladestecker
- Satz Drehteller S110A7/P
- 1 Bempedalfeststeller
- 1 Lenkradfeststeller
- 2 Paar STDA33EU 4-Punktrahalter

RAVTD2.0WIFI includes:

- Tablette
- kit de deux magnets adhésifs pour tablette
- Hub Wi-Fi
- Panneaux muraux pour ranger les têtes, équipés avec prise USB de recharge, support pour HUB Wi-Fi et support pour tablette
- Têtes de mesure à 8 CCD avec tige montée sur roulement, 1 encodeur et prise pour charge rapide
- Paire de plateau pivotants S110A7/P
- 1 pousse pédale
- 1 bloque-volant
- 2 Paires de griffes 4 points STDA33EU

RAVTD2.0WIFI incluye:

- Tableta
- Juego de imanes de alta calidad para la tableta
- Punto de acceso Wi-Fi
- Paneles de pared para el almacenamiento de los captadores con carga incorporada por USB, punto de acceso y soporte para la tableta
- Captadores de 8 cámaras CCD con pernos con rodamientos, 1 encoder y carga rápida
- Par de platos mecánicos S110A7/P
- 1 bloqueador de pedal de freno
- 1 bloqueador de volante
- 2 pares de garras de 4 puntos STDA33EU

**RICARICA RAPIDA
QUICK CHARGE**



**MIGLIORE UTILIZZO DELLO SPAZIO
BETTER USAGE OF FLOOR SPACE**



**PATENT
PENDING**



Due pannelli a parete per i sensori/ tablet con presa di carica USB (standard)

Two wall panels for storage and charge of the sensors/tablet (included).

Zwei Wand-Panele mit Ladestation der Messköpfe (inklusive)

Deux panneaux muraux pour rangement et charge des têtes et de la tablette

Dos paneles de pared para almacenamiento y carga de los captadores / tableta (incluidos)

La foto include pannelli opzionali STDA156
The picture includes optional panels STDA156

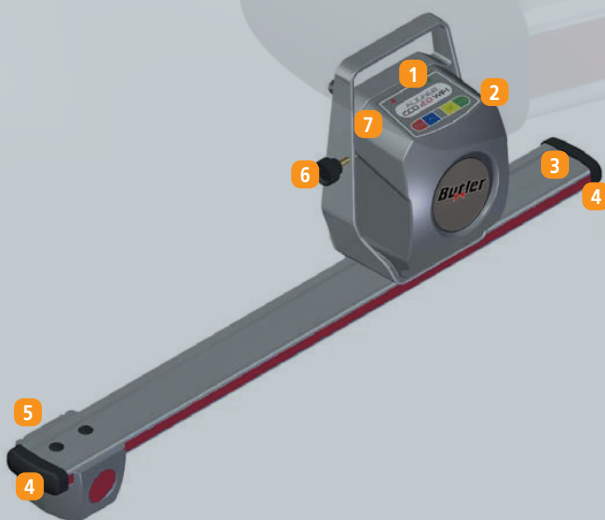

- 1 Luce verde = rilevatore in carica
Led rosso = rilevatore acceso
*Green led = detector is charging
Red led = detector on*
- 2 Rilevatore convergenza
Optical unit alignment
- 3 Alloggiamento batteria
Battery housing
- 4 Protezioni in gomma
Rubber protections
- 5 Rilevatore semi-convergenza
Optical unit toe-in
- 6 Perno di bloccaggio
Locking knob
- 7 Tastiera comando a distanza
Remote control keypad

NUOVE TESTE DI MISURA:

Wi-Fi, 8 sensori con cuscinetto ed encoder con prese di ricarica rapida.

NEW MEASURING HEADS:

Wi-Fi, 8 sensors with bearing and encoder with quick charging plugs.

NEUE MESSKÖPFE:

Wi-Fi, 8-CCD Sensoren mit kugelgelarten Bolzen, 1 Encoder und Schnelladekontakten

NOUVELLES TETES DE MESURE:

Wi-Fi à 8 capteurs, avec roulement et encodeur et prise de recharge rapide

NEVOS CAPTADORES:

Wi-Fi, 8 cámaras con pernos con rodamientos y encoder con enchufe de carga rápida.



SW completamente riscritto per iOS e Android con una nuova grafica e animazione. Tablet Android robusto incluso.

Complete porting of the SW to iOS and Android with new graphics and animation. Tablet Android rugged included.

Inklusive SW für iOS und Android mit neuer Grafik und neuen Animationen.

Inklusive sehr robustem Android-Tablet.

Logiciel d'exploitation (iOS ou Android) avec nouvelle interface graphique. Tablette professionnelle (avec protection) incluse.

El programa ha sido optimizado y adaptado a iOS y Android con una nueva gráfica y nuevas animaciones. La tableta robusta incluida es una Android rugged.

- Flessibilità nell'installazione e utilizzo ottimale dello spazio disponibile
- Tempi di installazione ridotti
- Design hi-tech
- *Flexibility in the installation and maximized use of the available space*
- *Reduced installation time*
- *Hi-tech design*
- Flexibel in der Installation und sehr platzsparend
- Reduzierter Installationsaufwand
- Hi-Tech-Design
- *Flexibilité d'installation et maximisation de l'espace disponible*
- *Temps d'installation réduit*
- *Nouveau design Hi-tech*
- Flexibilidad en la instalación y uso del espacio en el taller aprovechado al máximo
- Tiempos de instalación reducidos
- Diseño Hi-tech



EASY DATA



3D INFO



ANIMATION

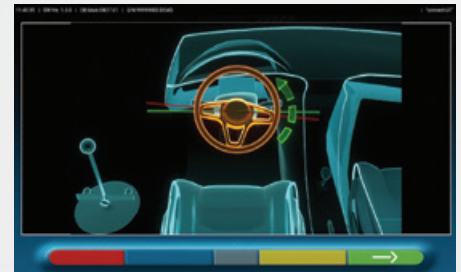

EASY ALIGNMENT



Istruzioni d'uso in grafica animata.

User's instructions by animated graphics.

Animierte Bedienungsführung

Instructions d'utilisation en graphisme animé.

Instrucciones de uso con gráficas animadas.



Possibilità di aggiungere una foto con dettagli del veicolo al rapporto di stampa.

Possibility to add one picture with vehicle details to the final report.

Foto vom Fahrzeug kann einfach in den Ausdruck integriert werden.

Possibilité d'ajouter au dossier client la photo du véhicule.

Possibilidad de añadir fácilmente una foto con detalles del vehículo a la impresión del informe.

E-MAIL



Possibilità di spedire i rapporti di prova direttamente via e-mail al cliente.

Send reports of measured vehicles directly to the customer via e-mail.

Messprotokoll kann per E-Mail verschickt werden.

Capacité d'envoyer le rapport d'épreuve par mail au client.

Possibilidad de enviar los informes de los alineados directamente por correo electrónico a los clientes.

UTILIZZABILE OVUNQUE! CAN BE USED ANYWHERE!

3 modi di fissaggio 3 fixing solutions

1

Magneti
Magnets



2

Antiscivolo
Antislip



3

Gancio
Hook



Kit magneti adesivi per la parte posteriore del tablet e supporto sospeso per fissaggio al ponte o al veicolo.

Kit adhesives magnets for the back of the tablet and hanging support to fix the tablet to the lift or to the vehicle.

Magnethalterung und Aufhängevorrichtung für das Tablet an der Hebebühne oder an das Fahrzeug.

La tablette suit l'opérateur sur le poste de travail: elle est fournie avec deux supports adhésifs magnétiques et un dispositif d'accroche.

Juego de imanes adhesivos para la parte trasera de la tableta; facilísimo fijar la tableta al elevador o al vehículo.

OPTIONS

Supporti per le graffe:
3 possibilità.

Clamps holders:
3 choices.

3 mögliche
Aufbewahrungen für
die Radhalter.

Trois possibilités pour
le rangement des
griffes.

Almacenamiento de
las garras:
3 posibilidades.

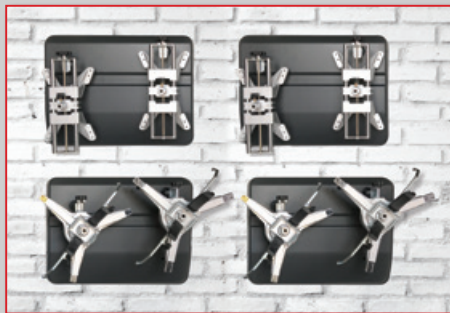

STDA156

2 pannelli a parete
2 wall panels
2 Wandpaneel
2 panneaux muraux
2 paneles de pared



STDA155

Carrello porta graffe, depressore pedale freno, blocco volante

Trolley holding clamps, brake pedal depressor, steering wheel lock.

Fahrgestell für Radhalter und Bremspedal- bzw Lenkradfeststeller.

Colonne sur roues pour griffes, pousse-pédale et bloque volant.

Carro para garras, bloqueador del pedal de freno y bloqueador de volante.



STDA157

4 supporti per fissure le graffe sul muro.

4 holders to fix the clamps on the wall.

4 Wandhalterungen für Radhalter.

4 crochets pour la fixation des griffes directement au mur.

4 soportes para fijar las garras a la pared.

CARATTERISTICHE TECNICHE	TECHNICAL FEATURES	TECHNISCHE EIGENSCHAFTEN	DONNÉES TECHNIQUES	CARACTERISTICAS TECNICAS	PRECISIONE ACCURACY MESSGENAUIGKEIT PRECISION PRECISIO	CAMPO DI MISURA MEASURING RANGE MESSBEREICH DOMAINE DE MESURE CAMPO DE MEDIA	CAMPO TOTALE DI MISURA TOTAL MEASURING RANGE GESAMTMESSBEREICH DOMAINE TOTAL DE MESURE CAMPO TOTAL DE MEDIA
Asse anteriore	Front axle	Vorderachse	Essieu avant	Eje delantero			
Convergenza	Total toe	Gesamtspur	Parallélisme total	Convergenca	+/- 2'	+/- 2°	+/- 20°
Semiconvergenza	Partial toe	Einzelspur	Parallélisme partiel	Convergenca parcial	+/- 1'	+/- 1°	+/- 20°
Deviazione asse	Set-back	Radversatz	Set-back	Desviación del eje	+/- 2'	+/- 2°	+/- 5°
Inclinazione ruota	Camber	Radsturz	Carrossage	Caida	+/- 2'	+/- 3°	+/- 10°
Incidenza montante	Caster	Nachlauf	Chasse	Avance	+/- 5'	+/- 10°	+/- 18°
Inclinazione montante	King pin	Spreizung	Inclinaison de pivot	Inclinación (king pin)	+/- 5'	+/- 10°	+/- 18°
Asse posteriore	Rear axle	Hinterachse	Essieu arrière	Eje trasero			
Convergenza	Total toe	Gesamtspur	Parallélisme total	Convergenca	+/- 2'	+/- 2°	+/- 20°
Semiconvergenza	Partial toe	Einzelspur	Parallélisme partiel	Convergenca parcial	+/- 1'	+/- 1°	+/- 20°
Deviazione asse	Set-back	Radversatz	Set-back	Desviación del eje	+/- 2'	+/- 2°	+/- 5°
Inclinazione ruota	Camber	Radsturz	Carrossage	Caida	+/- 2'	+/- 3°	+/- 10°
Angolo di spinta	Thrust angle	Fahrradswinkel	Angle de poussée	Angulo de empuje	+/- 2'	+/- 2°	+/- 5°

Butler

Engineering and Marketing S.p.A. a.s.u.
Via dell'Ecologia 6 - 42047 Rolo (RE)
Ph. +39-0522-647911 - Fax +39-0522-649760
www.butler.it - info@butler.it

a company

DBF15U (01)

Le caratteristiche tecniche e gli allestimenti presentati in questo prospetto possono subire variazioni. Le immagini riprodotte non sono vincolanti.

Technical data and composition presented in this catalogue may vary. Pictures reproduced are only indicative.

Die techn. Daten und die Ausrüstungen, die in diesem Prospekt enthalten sind, können Änderungen erfahren. Deshalb sind die Abbildungen unverbindlich.

Les caractéristiques techniques et les compositions présentées dans ce prospectus peuvent subir des variations. Les images reproduites n'ont qu'une valeur indicative.

Las características técnicas y las composiciones ilustradas en este folleto pueden sufrir variaciones. Las imágenes propuestas son solamente indicativas.