

PART LIST

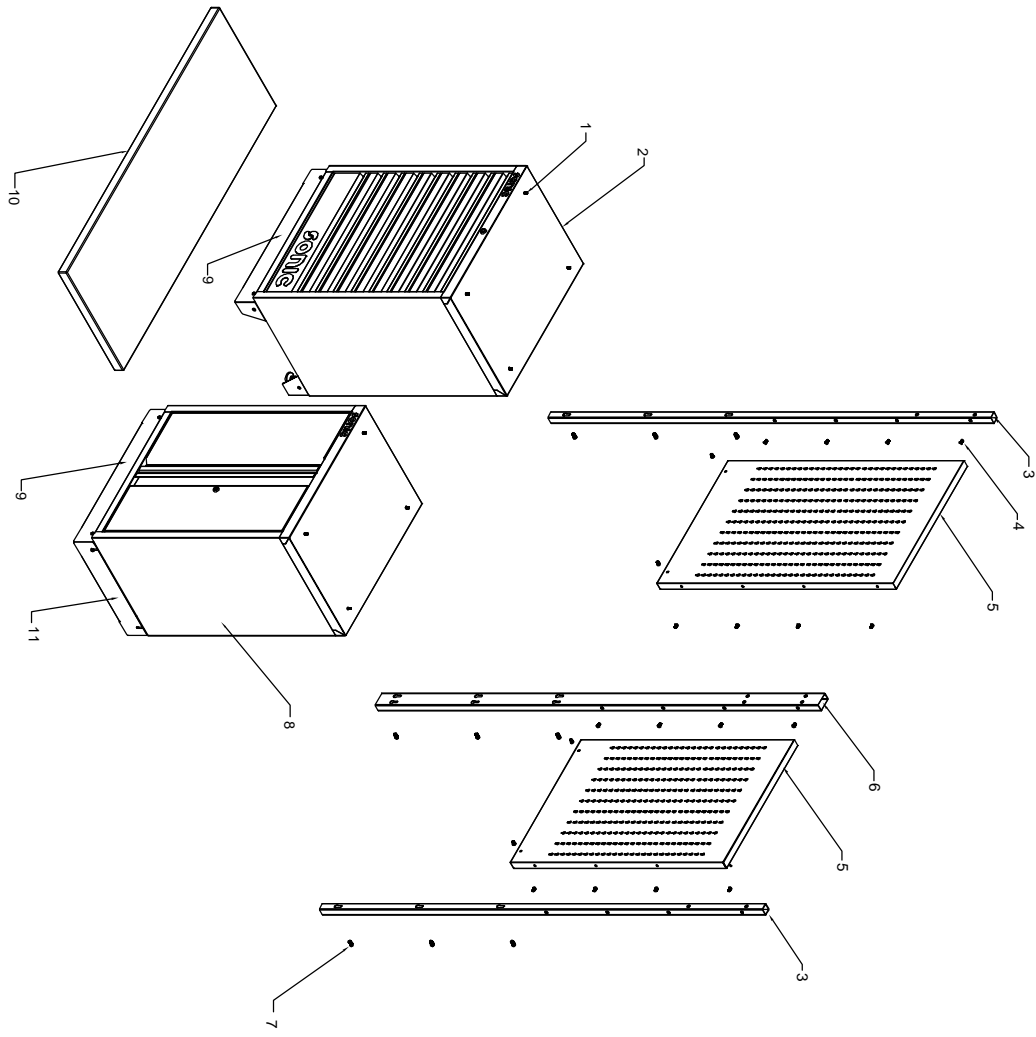

Ref#	Description	Part#	QTY
1	Hexagon bolt with flange screw (M6X25)		12 pcs
2	26" Cabinet frame	47280	1 pc
3	Pipe (30X30mm)	47284	2 pcs
4	Truss head screw (M6X12, stainless)		16 pcs
5	26" Hanger board	47376	2 pcs
6	Pipe (60X30mm)	47283	1 pc
7	HEX socket head cap screw (M8X20)		12 pcs
8	26" Closet frame	47288	1 pc
9	26" Skirting board	47289	2 pcs
10	52" Wooden work plate	47279	1 pc
11	26" Closet side board	47389	1 pc

ASSEMBLY INSTRUCTIONS

1. INSTALL ADJUSTABLE SHELF

Decide the height of the adjustable shelf onto the tongues on both side panels. Insert the bolts into the side panels. Place the shelf on the bolts. Make sure slot B go into box first.

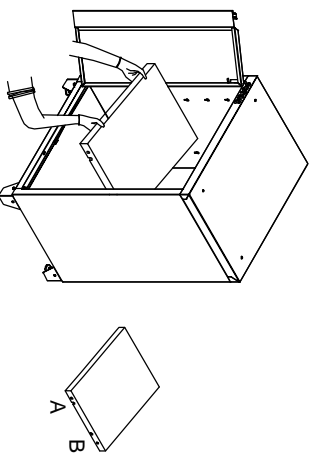

2. INSTALL PIPES

Simply position the pipes over the holes on the cabinets and attach with the bolts provided. Tighten HEX socket head cap screws (M8X20) securely.

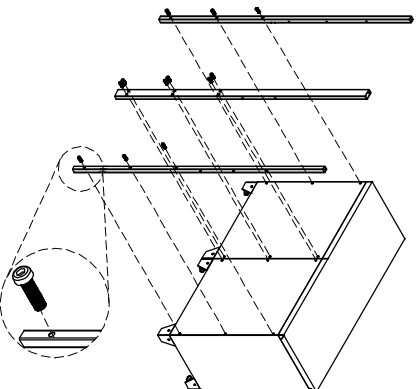

3. INSTALL HANGER BOARD

Simply position the hanger board over the holes and attach with the bolts provided. Tighten truss head screws (M6X12, stainless) securely.

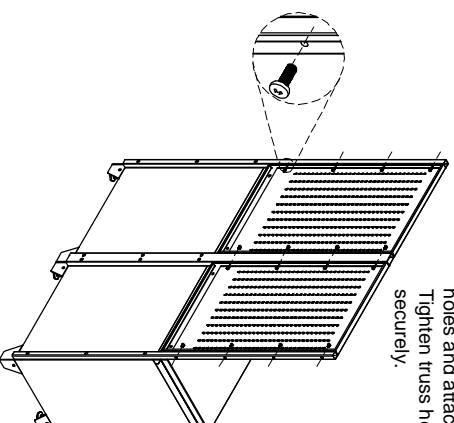

4. ADJUST LEVELER

Adjust the levelers and make the whole unit to stable state.

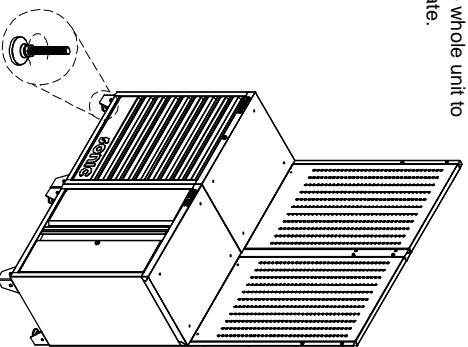

5. PRE-DRILL HOLES OF WOODEN WORK PLATE

Pre-drill eight small holes under the wooden work plate for easily installing. Repeat the steps for the back of wooden work plate (only four holes).

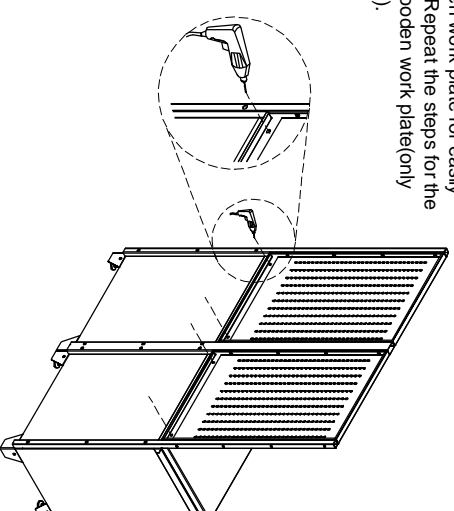

ASSEMBLY INSTRUCTIONS

6. INSTALL WOODEN WORK PLATE

Position the wooden work plate on the top of cabinets. Remove the top drawer of cabinets and open the 2-door cabinet. Insert the Hexagon bolt with flange screw (M6X25) through the top of cabinet, and into the bottom of the wooden worktop. Tighten securely. Reinstall the drawers.

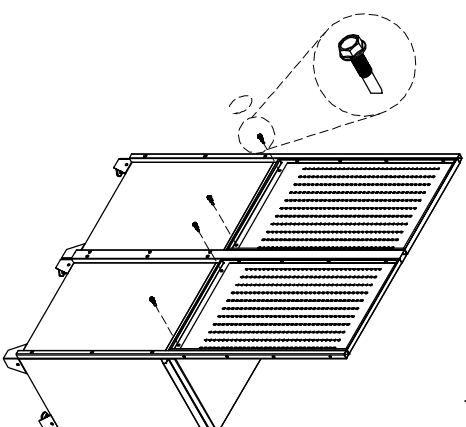
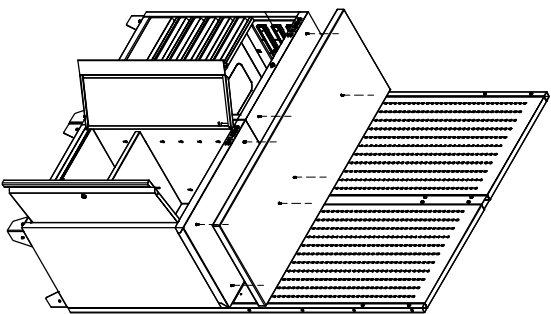

Insert the Hexagon bolt with flange screw (M6X25) through the back of hauger boards, and into the side of wooden work plate. Tighten securely.

7. INSTALL SKIRTING BOARDS

Position the skirting boards on the legs of cabinets. Insert the truss head screw (M6X12, stainless) through the legs. Tighten securely. Repeat the steps for other skirting boards.

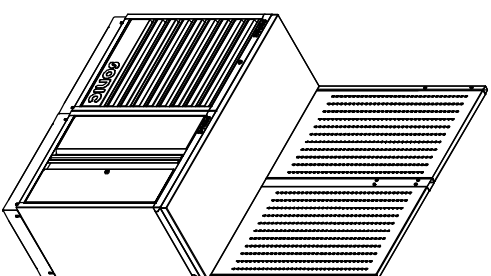
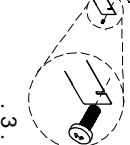
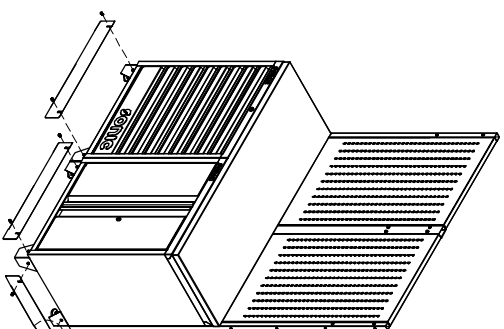

3.

