

PARTS LIST

Ref#	Description	Part#	QTY
1	Hexagon bolt with flange screw (M6X25)		12 pcs
2	26"Frame of Cabinet with door	47308	1 pc
3	26"Cabinet frame	47280	1 pc
4	26"Skirting board	47289	2 pcs
5	86"Wooden work plate	47306	1 pc
6	26"834"closet side board	47389	1 pc

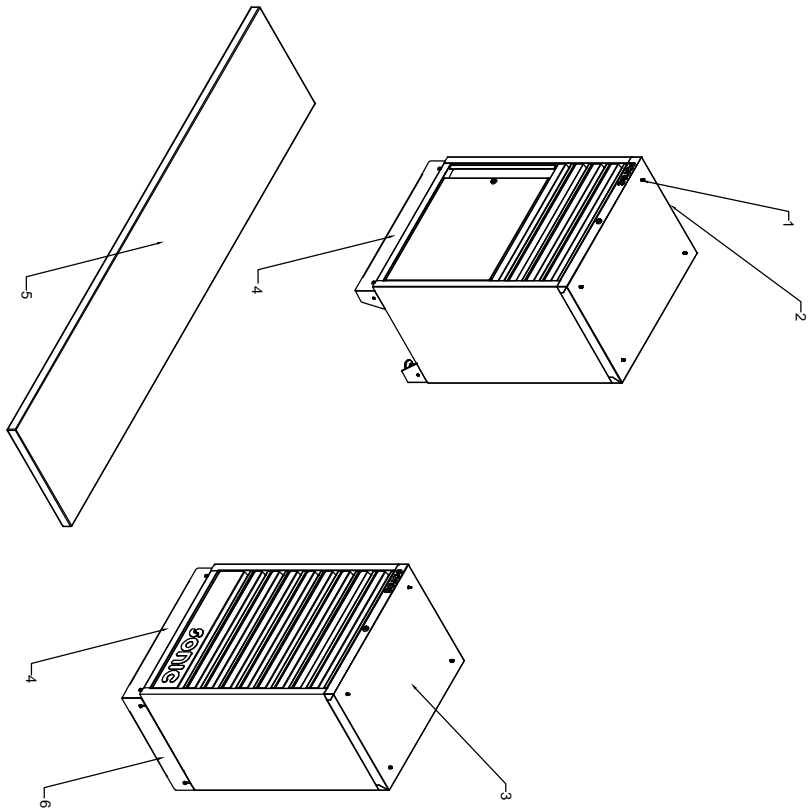

ASSEMBLY INSTRUCTIONS

1. ADJUST LEVELER

Adjust the levelers and make the whole unit to stable state.

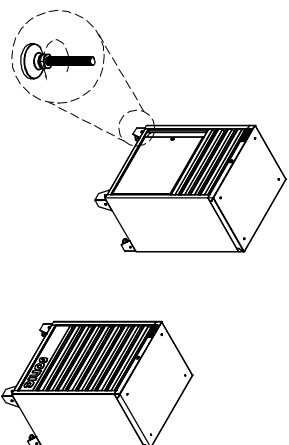

2. PRE-DRILL HOLES OF WOODEN WORK PLATE

Pre-drill eight small holes under the wooden work plate for easily installing.

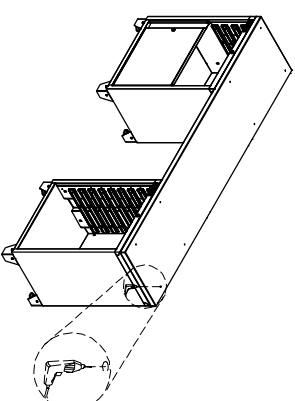

3. INSTALL WOODEN WORK PLATE

Position the wooden work plate on the top of cabinets. Remove the top drawer of cabinet. Insert the Hexagon bolt with flange screws (M6X25) through the top of cabinet, and into the bottom of the wooden worktop. Tighten securely. Reinstall the drawers.

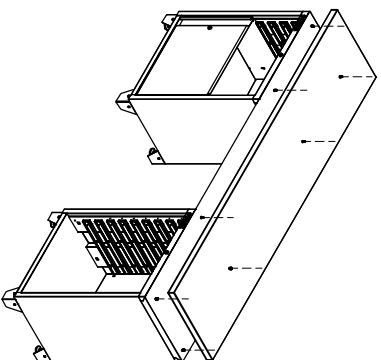

4. INSTALL SKIRTING BOARDS

Position the skirting boards on the legs of cabinets. Insert the Truss head screw (M6X12, stainless) through the legs. Tighten securely. Repeat the steps for other skirting boards.

